

# DHK-40L, DHK-60L, DHK-80L AIR BLOWER

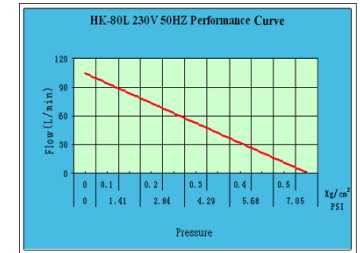

The state-of-the-art DHK type Air Blower has been launched by Dewatering Enterprise Co., Ltd. It originates in Taiwan, gaining CE certificate to ensure its quality. This model was designed for wastewater treatment, septic tanks and oxygen supply, which features efficient ventilation and low noise.



	A	B	C	D	E	F	G	H
DHK-40L								
DHK-60L								
DHK-80L	204	174	204	23	108	92	34	18

Model		DHK-40L	DHK-60L	DHK-80L			
Rated Voltage (V)		230V/120V					
Power supply frequency (Hz)		50	60	50	60		
Normal pressure (kgf /cm <sup>2</sup> )		0.13(1.85psi)		0.15(2.13psi)			
Exhaust quantity (L /min)		50	47	72	66	84	82
Power (w)		41	37	59	62	78	84
Noise level (dB)		35	32	38	37	39	39
Closed pressure	psi	5.7	5.7	7.1	6.4	7.8	7.8
	Kgf /cm <sup>2</sup>	0.4	0.4	0.5	0.45	0.55	0.55
Weight (kg)		5.4	5.4	6.26	6.26	6.28	6.28

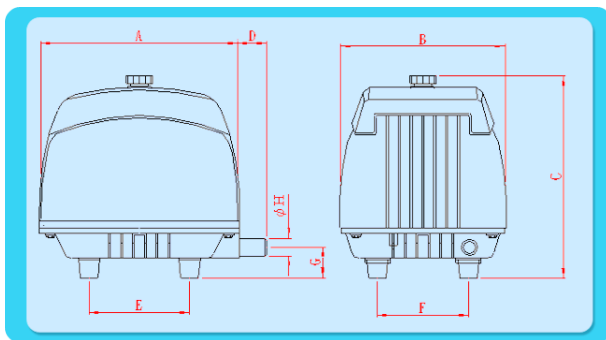

# DHK-100L, DHK-120L AIR BLOWER



The state-of-the-art DHK type Air Blower has been launched by Dewatering Enterprise Co., Ltd. It originates in Taiwan, gaining CE certificate to ensure its quality. This model was designed for wastewater treatment, septic tanks and oxygen supply, which features efficient ventilation and low noise.

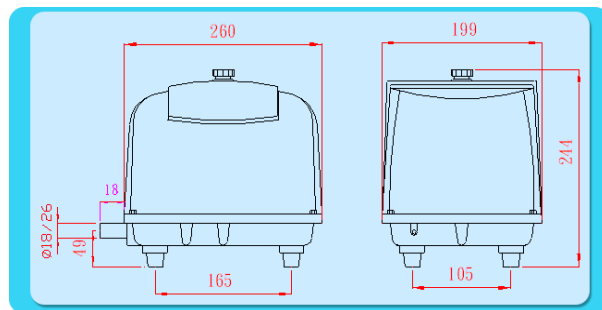
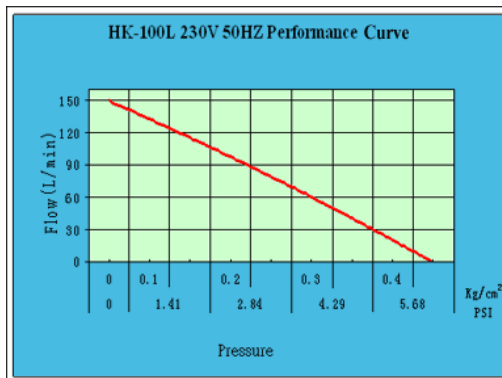

	DHK-100L		DHK-120L		
Rated Voltage (V)	230V/120V				
Power supply frequency (Hz)	50	60	50	60	
Normal pressure (kgf / cm <sup>2</sup> )	0.18(2.56psi) 0.2(2.84psi)				
Exhaust quantity (L / min)	106	105	125	123	
Power (w)	94	110	130	130	
Noise level (dB)	44	45	46	47	
Closed pressure	psi	6.4	7.1	7.1	7.8
	Kgf / cm <sup>2</sup>	0.45	0.5	0.5	0.55
Weight (kg)	8.9	8.9	8.9	8.9	